

CT 27-ZP4

Short Centre-loaded Mobile Antenna
for the 27 MHz CB-Band

PROCOM



DESCRIPTION:

- ★ Short antenna with attractive appearance ideal for mounting on the car roof.
- ★ High efficiency in spite of low height due to high-Q centre-loading coil and matching unit built into mount.
- ★ Stainless steel ZP4-mount, with ball-joint and wing screw whip-fastening system.
- ★ Simple mounting exclusively with access from the outside.
- ★ Delivered with 4 m cable permanently attached to the mount and terminated with FME-connector.

SPECIFICATIONS:

ELECTRICAL	
ANTENNA TYPE	Centre-loaded mobile antenna
FREQUENCY	27 MHz CB-band
IMPEDANCE	Nom. 50 Ω
POLARISATION	Vertical
BANDWIDTH	≥ 350 kHz at SWR ≤ 1.5
SWR	≤ 1.3
MAX. POWER	200 watt
MECHANICAL	
MATERIALS	Whip: Stainless steel Nylon
	Mount: Chromed brass Environment-proof plastics Stainless steel
RECOMMENDED INSTALLATION TORQUE	7.5 \pm 1 Nm
CABLE	4 m RG 58
COLOUR	Bright/black
HEIGHT	Approx. 0.68 m (0.06 λ)
WEIGHT	Approx. 490 g
MOUNTING	21 mm dia. hole

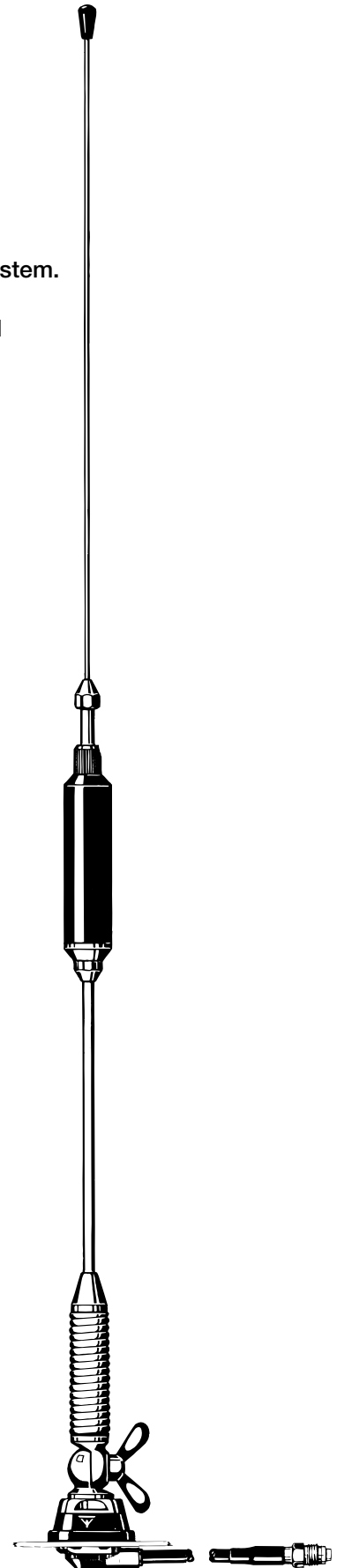

CT 27-ZP4 Installation



This antenna is supplied with type ZP4-mount. The whip is fastened to the mount by means of our standard ball-joint and wing screw system. The adjustable ball-joint ensures that the whip can always be mounted in a vertical position independent of the angle of the installation spot.

The ZP4-mount is particularly well suited for mounting on car-roofs because of its ability to be installed exclusively with access from the outside. However, the antenna can be installed anywhere on the car, as the ZP4-mount is equally well suited for mounting on e.g. trunk or wing.

1. INSTALLATION DIMENSIONS:

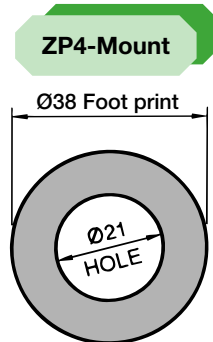

Build-in depth: 10.5 mm

2. INSTALLATION STEPS:

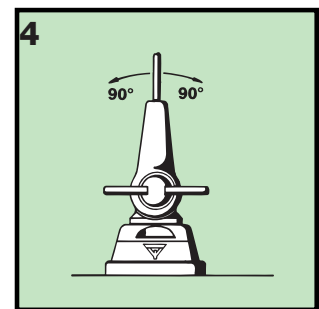
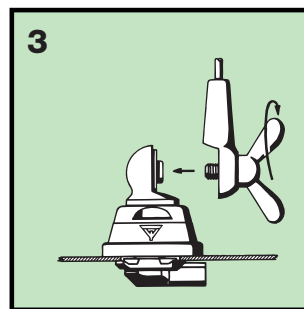
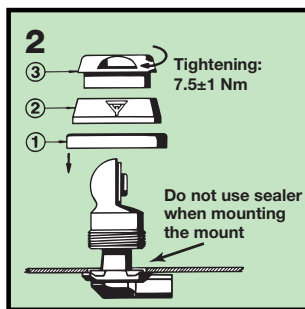
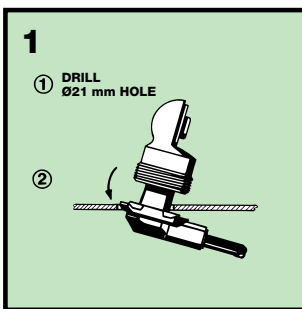

3. TUNING:

The antenna should always be post-adjusted using an SWR-meter, especially if mounted near metal parts parallel to the whip. Loosen the union nut at the top of the coil and pull out the whip approx. 5 mm at a time until best possible SWR is obtained. Fasten the union nut thoroughly.

PLEASE NOTE:

To make this antenna operate as efficiently as possible, a matching unit has been built into the antenna mount. Consequently, neither mount nor whip can be used together with other mounts/whips.