

# GF 1804

## Mobile GlassFix® Antenna for the 1800 MHz Band

**PROCOM**

### DESCRIPTION:

- ★ Colinear mobile antenna for the 1800 MHz band (e.g. DCS-1800/PCN) using the GlassFix® mounting principle.
- ★ Mounting on car window glass – no holes required.
- ★ Instant-adhesion procedure ensures fast and reliable fixing.
- ★ Internal matching unit feeds external antenna through window glass.
- ★ Half-wave colinear design – no ground plane required.
- ★ FME FastCabling system (cable to be ordered separately).
- ★ Simple tuning procedure by means of tuning screw on matching unit.
- ★ Easy removable whip for car wash.
- ★ Swivel joint for 180° angle adjustment.
- ★ If removal of antenna installation is necessary, a quick dismantling procedure leaves no trace of the installation.

### ASSEMBLY DETAILS:

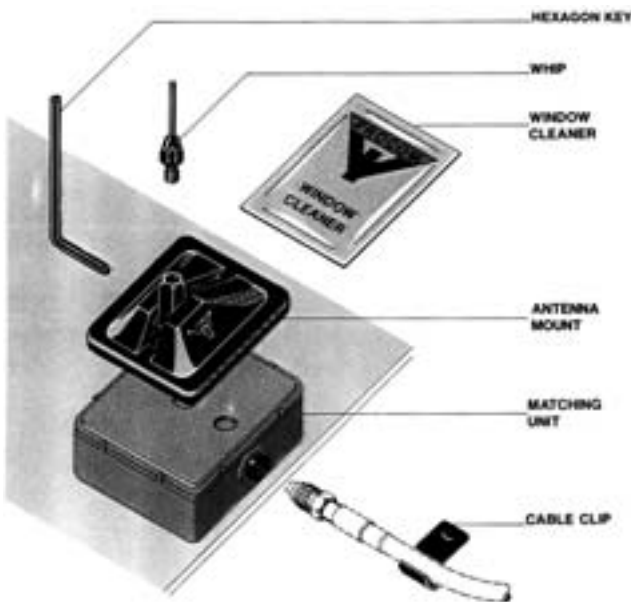

### SPECIFICATIONS:

ELECTRICAL	
ANTENNA TYPE	Colinear mobile GlassFix® antenna
FREQUENCY	1800 MHz-band (1700–1900 MHz)
IMPEDANCE	Nom. 50 Ω
POLARISATION	Vertical
BANDWIDTH	≥ 170 MHz (SWR ≤ 1.75)
SWR	≤ 1.3 at f. res.
MAX. POWER	25 watt
MECHANICAL	
MATERIALS	Whip: Stainless steel and brass, black-chromed Mount and indoor unit: Environment-proof plastics Corrosion-safe and corrosion-protected metals
CABLE	FME-cable to be ordered separately
COLOUR	Black
HEIGHT	Approx. 110 mm
WEIGHT	Approx. 60 g
MOUNTING	On car windows (52 mm x 47 mm obstruction-free mounting area required)
GLASS THICKNESS	2.5 – 7.0 mm

#### FME-SYSTEM ACCESSORIES

##### FME-CABLES

LENGTH	TYPE NO.
1m	1m FME
2m	2m FME
3m	3m FME
4m	4m FME
5m	5m FME
6m	6m FME
4m white	4m FME-white
6m white	6m FME-white
12m white	12m FME-white
18m white	18m FME-white

For further information about other types of FME-cables please compare the cable data sheets under accessories in our catalogue.

#### FME-CONNECTORS

CONNECTOR	ORDER NO.
FME-FME	FME-FME
Prolongation	FMEP
N	FME-N
FSMA	FME-FSMA
BNC	FME-BNC
TNC	FME-TNC
UHF	FME-UHF
Mini-UHF	FME-MUHF
Elbow-MUHF	FME-EMUHF
Elbow-BNC	FME-EBNC
Elbow-TNC	FME-ETNC
SMA	FME-SMA

#### Glue Option:



For the antenna to be delivered with silicone glue to secure the mount using a double-adhesion procedure, add an M to the antenna designation: GF 1804M.

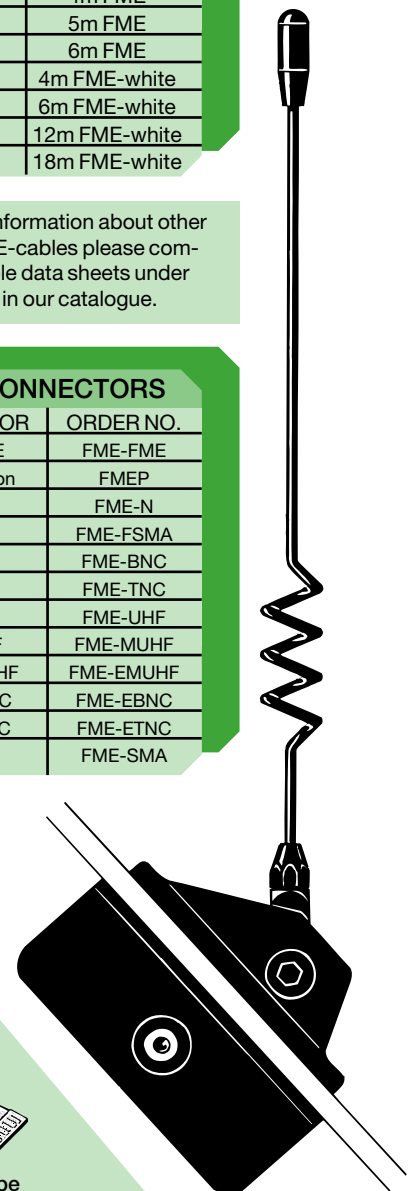

# GF 1804 Installation



## 1. BEFORE INSTALLATION:

- ★ When selecting mounting location take into consideration: positions of back view mirror, wiper blade paths and defogger wires (when mounting on rear window). The driver's view should not be obstructed.
- ★ Max. allowed curvature of the glass surface on the mounting spot is 2 mm deflection per 100 mm length.
- ★ Environmental- and car temperature must be above 15° C at installation, and installation surfaces must be dry and clean.

## 2. INSTALLATION:

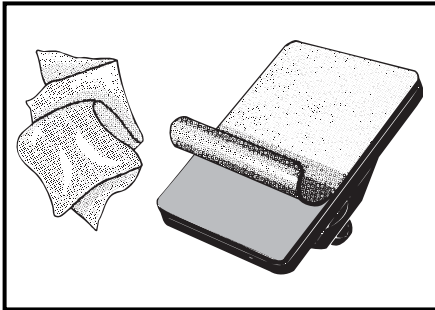

1. Clean both sides of the windscreen, where the antenna mount and the matching unit are to be fitted, and then remove the protective foil from the antenna mount.

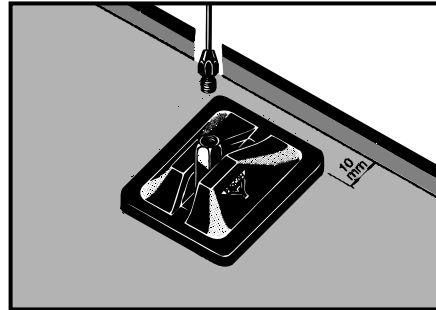

2. Fit mount to screen and press firmly with twisting movements. Apply pressure on both plastic cover and antenna holder. Repeat 2-3 times. Fit the antenna whip.

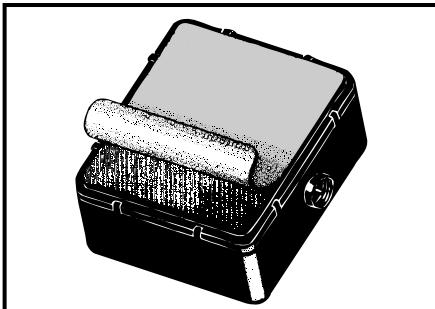

3. Remove the protective foil from the matching unit.

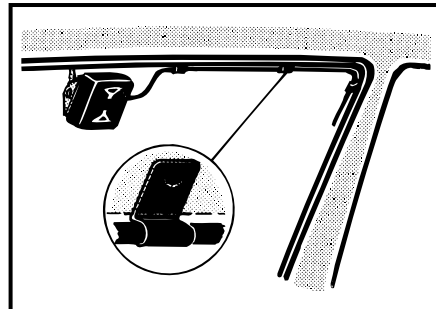

4. Fit matching unit by pressing it firmly into position. Secure cable using clips provided.

## 3. TUNING INSTRUCTIONS:

- ★ Insert a forward/reflection-type wattmeter between the transmitter and the antenna.
- ★ Key the transmitter and observe the forward and the reflected power.
- ★ Adjust the tuning screw on the matching unit until minimum returned power is obtained. For duplex operation, the antenna can be off-tuned slightly to favorize the matching on the RX. Turning the screw clockwise will shift the antenna resonance to a lower frequency and vice versa. The SWR on the TX should, however, never exceed 1:1.5.

## 4. ADHESION ADVICE:

- ★ It is essential for a good adhesion result that the surfaces are properly cleaned and dry.
- ★ A high application pressure improves the binding power.
- ★ Ideal application temperature range is +20° C to +38° C but may be extended down to +15° C. When applied, binding strength is maintained between -30° C and +70° C.
- ★ Binding power increases considerably with time. To ensure full strength of the assembly it is recommended to keep the whip off the mount for 24 hours.
- ★ To accelerate attainment of full binding power, the joined parts may be heat-treated with a warm-air gun.  
PLEASE NOTE: Do not heat parts to more than 65° C and take care not to spoil other nearby car parts.

## REINSTALLATION KIT:

A reinstallation kit including all necessary parts for transfer of the antenna to another vehicle is available under order No. »GF-RK 900«.

## WARNING: SAFETY PRECAUTIONS

- ★ Antennas mounted on the windscreen may cause relatively high field strengths in the passenger cabin and near the dashboard.
  1. To prevent health hazard due to RF radiation, persons must not be closer than 30 cm to the antenna whip (transmitter output power to the matching unit: 20 watt). (DIN 57 848).
  2. The RF signals at the dashboard may cause interference in the car's electronic equipment such as broadcast radio, computer automatics, braking systems, electronic ignition, relays etc. Some cars are more susceptible to disturbances than others.  
It is the responsibility of the installer to carry out a thorough check of the proper functioning under any conditions of such circuits before finishing installation.