

# MH 1-LXR

1/4  $\lambda$  Mobile Antenna for the 160 MHz Band

PROCOM

## DESCRIPTION:

- ★ 0 dB mobile antenna.
- ★ Black-chromed, conical stainless steel whip.
- ★ Stainless steel LX-mount – professional quality in elegant and smooth design.
- ★ Especially suited for roof-mounting.
- ★ Provided with FME-connection (supplied without cable).
- ★ Bendable section in mount for adjustment of whip (tiltable 15° by hand).
- ★ Installation with access from the outside only (requiring an 18 mm dia. hole).



## SPECIFICATIONS:

ELECTRICAL	
ANTENNA TYPE	1/4 $\lambda$ mobile whip antenna
FREQUENCY	Tunable by cutting within: 144...175 MHz (Also applicable: 175...225 MHz)
IMPEDANCE	Nom. 50 $\Omega$
POLARISATION	Vertical
GAIN	0 dB (acc. to EIA RS-329)
BANDWIDTH	$\geq 15$ MHz at SWR $\leq 2.0$
SWR	$\leq 1.3$ at f. res.
MAX. POWER	100 watt
MECHANICAL	
MATERIALS	Whip: Black-chromed stainless steel Black-chromed brass Mount: Stainless steel Brass Environment-proof plastics
RECOMMENDED INSTALLATION TORQUE	3.5 Nm max.
CABLE	FME-cable to be ordered separately
COLOUR	Black
HEIGHT	Approx. 550 mm
WEIGHT	Approx. 52 g
MOUNTING	18 mm dia. hole

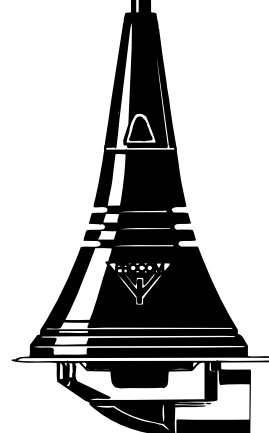

# MH 1-LXR

## Installation



The LX-mount is especially suited for roof-mounting. It is recommended to mount the antenna at the centre of the roof to ensure the best omnidirectional coverage. Mounting can take place in an 18 mm dia. hole with access from the outside only. When cleaning the car in car-washing machines, the whip should be removed – a 9 mm fork spanner can be used. After wash, the whip is refitted and tightened lightly with the spanner. The mount is equipped with a bendable section ( $\pm 15^\circ$ ) to make it possible to adjust the antenna to an upright position.

### 1. INSTALLATION DIMENSIONS:

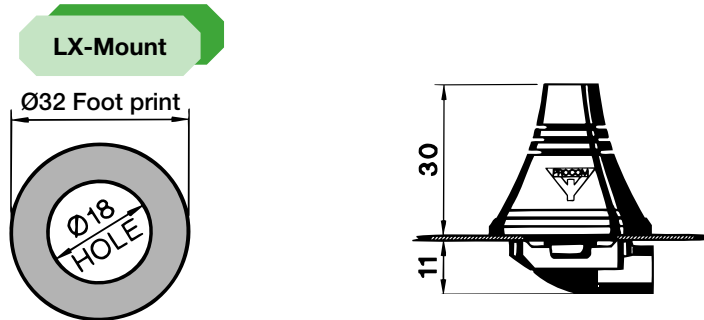

### 2. INSTALLATION STEPS:

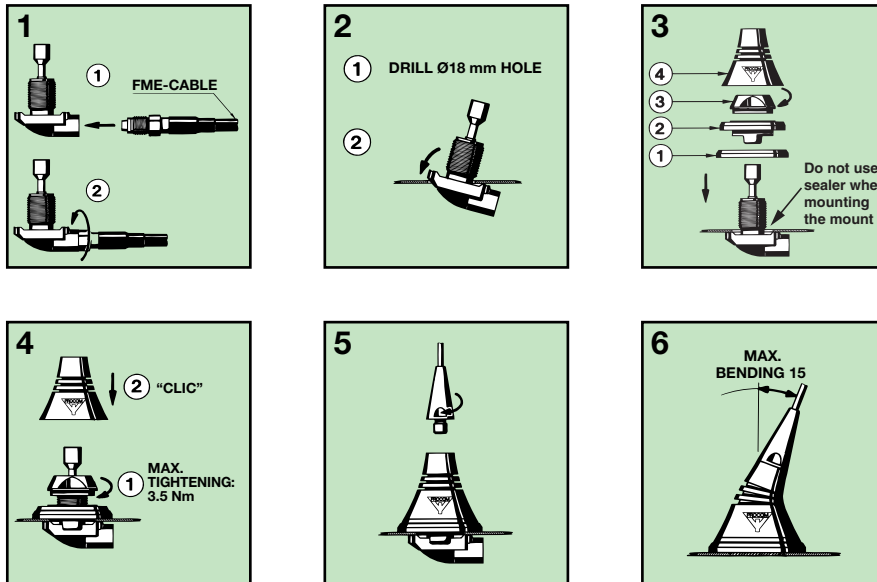

**PLEASE NOTE:** When tightening the revolving nut (see picture 4), special care must be taken to keep the spanner in the correct position.

### 3. TUNING/MODEL CONVERSION:

The antenna should always be tuned using an SWR-meter. The cutting diagrams below serve as a guide for this procedure.

