

# MU 23-3-ZG

**Colinear 3 dB Mobile Antenna for the 23 cm Amateur Band: 1240–1300 MHz**

**PROCOM**

## DESCRIPTION:

- ★ 3 dB colinear whip comprising a  $3/8 \lambda$  section, a phasing coil and a  $5/8 \lambda$  section.
- ★ All materials in top professional quality.
- ★ Broadband-performance 1240–1300 MHz – no tuning required.
- ★ Stainless steel ZG-mount with M8 x 1-thread whip-fastening system.
- ★ Simple mounting in a 21 mm hole with access from the outside only.
- ★ Choice between two connection principles:
  - ★ ZG-mount : FME-connection (supplied without cable).
  - ★ ZGP4-mount : Permanently attached 4 m low-loss RG 58 cable terminated with FME-connector.

### FME-SYSTEM ACCESSORIES

#### FME-CABLES

LENGTH	TYPE NO.
1m	1m FME
2m	2m FME
3m	3m FME
4m	4m FME
5m	5m FME
6m	6m FME
4m white	4m FME-white
6m white	6m FME-white
12m white	12m FME-white
18m white	18m FME-white

For further information about other types of FME-cables please compare the cable data sheets under accessories in our catalogue.

### FME-CONNECTORS

CONNECTOR	ORDER NO.
FME-FME	FME-FME
Prolongation	FMEP
N	FME-N
FSMA	FME-FSMA
BNC	FME-BNC
TNC	FME-TNC
UHF	FME-UHF
Mini-UHF	FME-MUHF
Elbow-MUHF	FME-EMUHF
Elbow-BNC	FME-EBNC
Elbow-TNC	FME-ETNC
SMA	FME-SMA

## ORDERING DESIGNATIONS:

MOUNT VERSION	ZG-mount with FME-system	ZGP4-mount with 4 m cable and FME-connector
TYPE NO.	MU 23-3-ZG	MU 23-3-ZGP4

## SPECIFICATIONS:

ELECTRICAL	
ANTENNA TYPE	Colinear mobile antenna
FREQUENCY	23 cm amateur band: 1240–1300 MHz
IMPEDANCE	Nom. 50 $\Omega$
POLARISATION	Vertical
GAIN	3 dB (acc. to EIA RS-329)
BANDWIDTH	$\geq 60$ MHz at SWR $\leq 2.5$
SWR	$\leq 2.0$ at f. res.
MAX. POWER	40 watt
MECHANICAL	
MATERIALS	Whip: Black-chromed stainless steel and brass Mount: Black-chromed brass Environment-proof plastics Stainless steel
RECOMMENDED INSTALLATION TORQUE	7.5 $\pm$ 1 Nm
COLOUR	Black
HEIGHT	Approx. 22 cm
WEIGHT	ZG-version : Approx. 120 g ZGP4-version: Approx. 260 g
MOUNTING	21 mm dia. hole

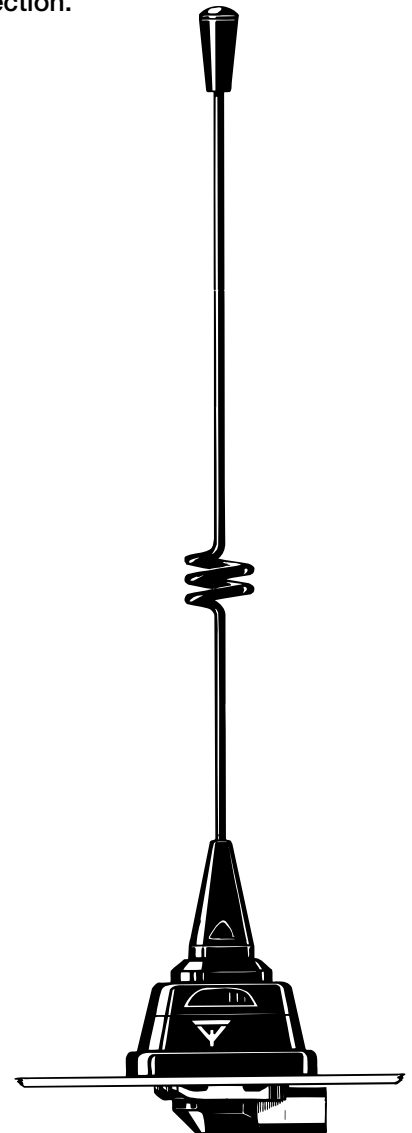

### ZG-Mount

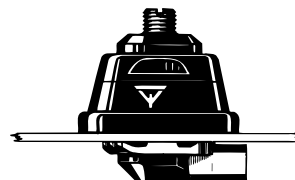

### ZGP4-Mount

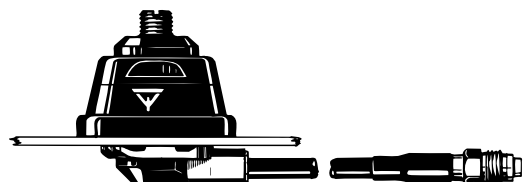

PROCOM A/S reserve the right to amend specifications without prior notice.

# MU 23-3-ZG Installation



This antenna should be mounted on the car roof to ensure best omnidirectional coverage. The antenna is provided with our type ZG-mount for mounting from the outside in a 21 mm dia. hole.  
The ZG-mount is provided with an M8 x 1 thread mount system. This construction meets the demand for a low-profile mobile mount with a slim appearance and with protection against theft of the antenna whip.  
When cleaning the car in automatic washing machines, the whip is easily removed using a spanner, size 12 mm. The whip is refitted again by screwing it onto the M8 x 1 thread stud and tightening it with the spanner.

## 1. INSTALLATION DIMENSIONS:

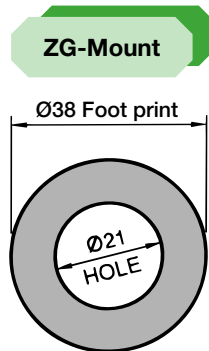

Build-in depth: 10.5 mm

## 2. INSTALLATION STEPS:

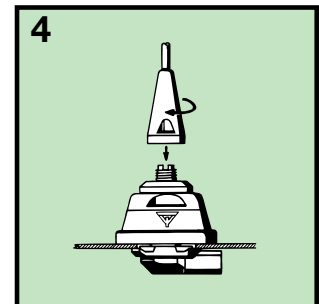
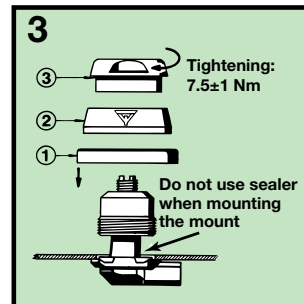
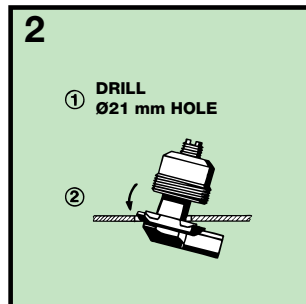
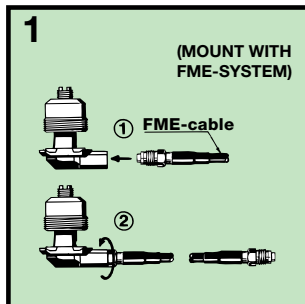

## 3. TUNING:

The antenna is delivered factory-tuned and requires no further tuning.