

MU 5-X/...

Unity Gain $1/4 \lambda$ Mobile Antenna for the 450 MHz Band

PROCOM

DESCRIPTION:

- ★ Sturdy, conical, flexible rubber whip.
- ★ MU 5-X/s covers 370–410 MHz
MU 5-X/l covers 406–440 MHz
MU 5-X/h covers 430–470 MHz
– no tuning required.
- ★ Stainless steel X-mount with M6-thread whip-fastening system.
- ★ Simple mounting exclusively with access from the outside.
- ★ Models available with X-mount (oblong), CX-mount (circular) and MM-mount (magnetic).
- ★ Choice between two connection principles:
 - ★ X-mount, MM-mount: FME-connection (supplied without cable).
 - ★ XP4-mount : Permanently attached 4 m cable terminated with FME-connector.

SPECIFICATIONS:

ELECTRICAL	
ANTENNA TYPE	$1/4 \lambda$ mobile whip antenna
FREQUENCY	450 MHz band covered by three models
IMPEDANCE	Nom. 50 Ω
POLARISATION	Vertical
GAIN	0 dB (acc. to EIA RS-329)
BANDWIDTH	≥ 45 MHz at SWR ≤ 1.5
SWR	≤ 1.2 at f. res.
MAX. POWER	100 watt
MECHANICAL	
MATERIALS	Whip: Sturdy, flexible rubber with cast-in multicore steel wire radiating element Black-chromed brass Mount: Black-chromed brass Environment-proof plastics Stainless steel
RECOMMENDED INSTALLATION TORQUE	4 ± 1 Nm
COLOUR	Black
HEIGHT	Approx. 170 mm
WEIGHT	X-version : Approx. 75 g XP4-version : Approx. 215 g MM-version : Approx. 325 g
MOUNTING	18 mm dia. hole

All whips are compatible with all mounts.

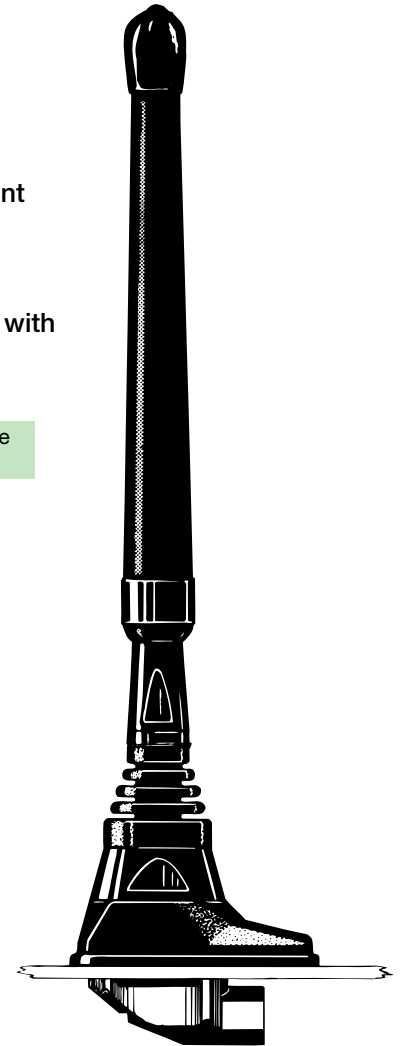

X-Mount

CX-Mount

XP4-Mount

CXP4-Mount

MM-Mount

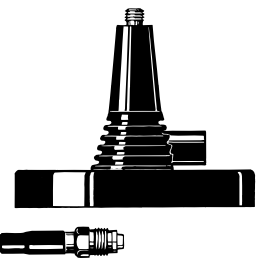
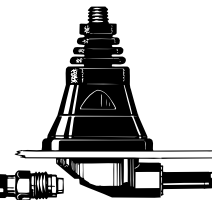
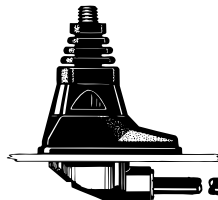
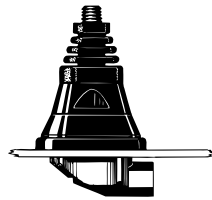
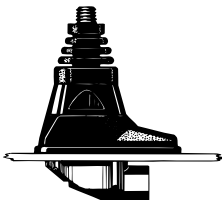

ORDERING DESIGNATIONS:

FRE-QUENCY RANGE / MOUNT VERSION	X-mount (oblong) with FME-system	CX-mount (circular) with FME-system	XP4-mount (oblong) with 4 m cable + FME-connector	CXP4-mount (circular) with 4 m cable + FME-connector	MM-mount (magnetic) with FME-system
370–410 MHz	MU 5-X/s	MU 5-CX/s	MU 5-XP4/s	MU 5-CXP4/s	MU 5-MM/s
406–440 MHz	MU 5-X/l	MU 5-CX/l	MU 5-XP4/l	MU 5-CXP4/l	MU 5-MM/l
430–470 MHz	MU 5-X/h	MU 5-CX/h	MU 5-XP4/h	MU 5-CXP4/h	MU 5-MM/h

PROCOM A/S reserve the right to amend specifications without prior notice.

MU 5-X/... Installation



This antenna should be mounted on the car roof to ensure best omnidirectional coverage.

Mounting can take place exclusively with access from the outside when drilling an 18 mm dia. hole. Mounting can take place from the inside by drilling a 14 mm dia. hole. When mounting in a 14 mm dia. hole, remove the bottom plastic ring of the packing gasket with a sharp cutter.

When cleaning the car in car-washing machines, remove the whip using a spanner, size 9 mm. After wash, refit the whip and tighten it lightly with the spanner.

The MiniMag (abbreviated: MM) is a small, light-weight magnetic mount with a high attaching effect. A silicone layer applied to the contact surface protects the car roof and ensures maximum friction.

1. INSTALLATION DIMENSIONS:

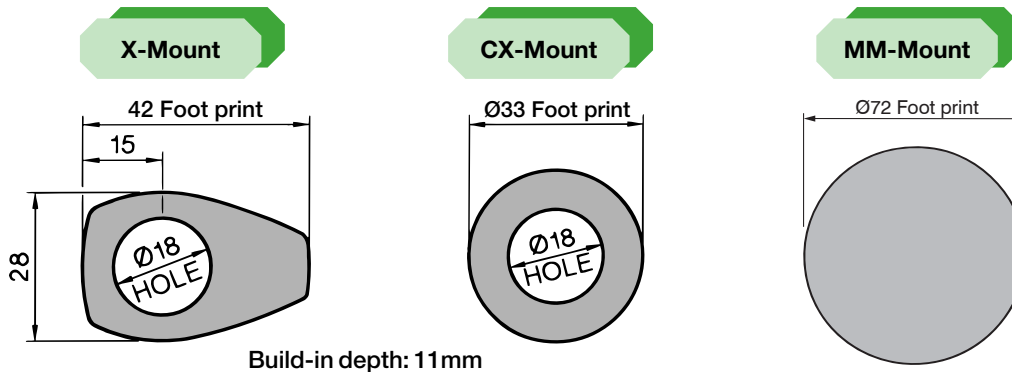

2. INSTALLATION STEPS:

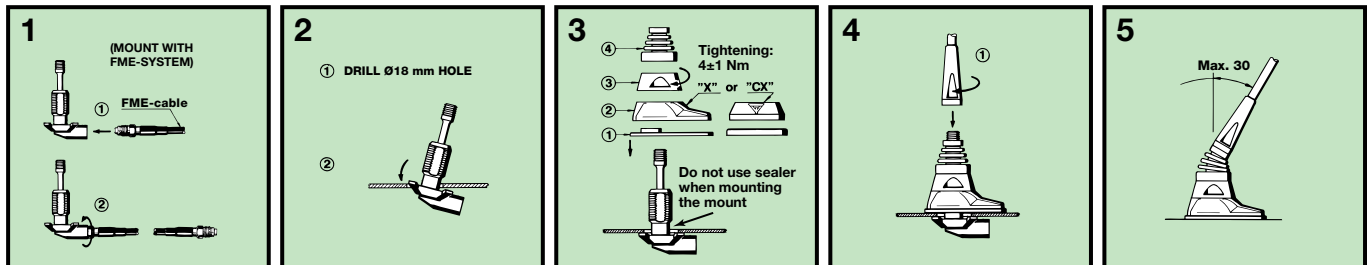

3. TUNING/MODEL CONVERSION:

The antenna is delivered factory-tuned and requires no further tuning.

To convert an MU 5-X/s model into an MU 5-X/l model, cut off 12 mm of the top end of the whip.

To convert an MU 5-X/l model into an MU 5-X/h model, cut off 11 mm of the top end of the whip.

PLEASE NOTE:

For safety reasons:

1. When using the MU 5-MM, car speed must not exceed 140 km/h.
2. If operating the MM-mount with other whips, whip length must never exceed 60 cm, and utilizing this maximum length, car speed must not exceed 115 km/h.