

MU 907-ZG/...

Unity Gain $1/4 \lambda$ Mobile Antenna
for the 900 MHz Band



DESCRIPTION:

- ★ Silicone covered flexible steel wire whip.
- ★ Type MU 907-ZG/l covers 820–905 MHz (e.g. for EAMPS).
Type MU 907-ZG/h covers 870–960 MHz (e.g. for ETACS, NMT-900 and EGSM).
- ★ Stainless steel ZG-mount with M8 x 1-thread whip-fastening system.
- ★ Simple mounting exclusively with access from the outside.
- ★ Choice between two connection principles:
 - ★ ZG-mount : FME-connection (supplied without cable).
 - ★ ZGP4-mount : Permanently attached 4 m low loss cable terminated with FME-connector.

ZG-Mount

ZGP4-Mount

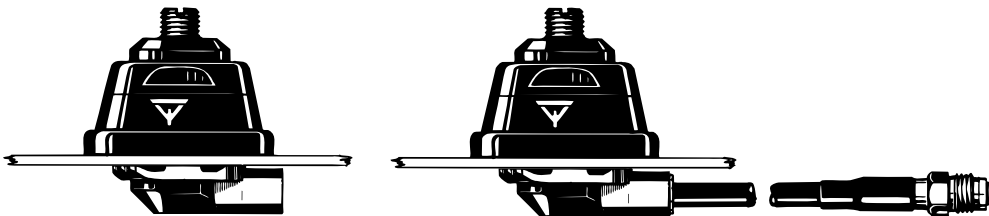

ORDERING DESIGNATIONS:

FRE-QUENCY RANGE	MOUNT VERSION	ZG-mount with FME	ZGP4-mount with 4 m cable and FME-connector
820–905 MHz		MU 907-ZG/l	MU 907-ZGP4/l
870–960 MHz		MU 907-ZG/h	MU 907-ZGP4/h

SPECIFICATIONS:

ELECTRICAL	
ANTENNA TYPE	$1/4 \lambda$ mobile antenna
FREQUENCY	900 MHz-band covered by two models
IMPEDANCE	Nom. 50Ω
POLARISATION	Vertical
GAIN	0 dB (acc. to EIA RS-329)
BANDWIDTH	≥ 80 MHz at SWR ≤ 1.5 ≥ 170 MHz at SWR ≤ 2.0
SWR	≤ 1.2 at f. res.
MAX. POWER	60 watt
MECHANICAL	
MATERIALS	Whip: Steel wire covered with silicone tubing Black-chromed brass Mount: Black chromed brass Environment-proof plastics Stainless steel
RECOMMENDED INSTALLATION TORQUE	7.5 ± 1 Nm
COLOUR	Black
HEIGHT	Approx. 91 mm
WEIGHT	ZG-version : Approx. 90 g ZGP4-version : Approx. 230 g
MOUNTING	21 mm dia. hole

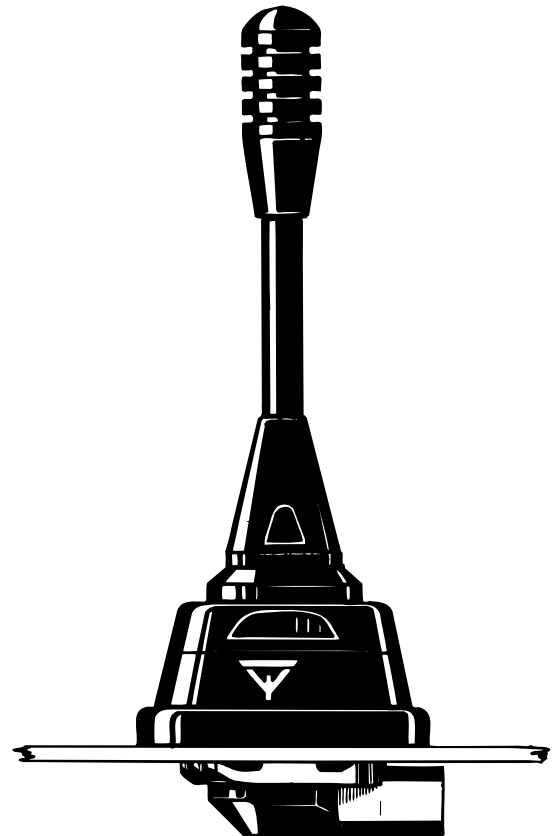

To help selecting the correct model for a specific cellular network please consult the survey of cellular network frequencies under USEFUL DATA in our catalogues.

PROCOM A/S reserve the right to amend specifications without prior notice.

MU 907-ZG/...

Installation



This antenna should be mounted on the car roof to ensure best omnidirectional coverage. The antenna is provided with our type ZG-mount for mounting from the outside in a 21 mm dia. hole.

The ZG-mount is provided with an M8 x 1 thread mount system. This construction meets the demand for a low-profile mobile mount with a slim appearance and with protection against theft of the antenna whip.

When cleaning the car in car-washing machines, the whip is easily removed using a spanner, size 12 mm. The whip is refitted again by screwing it onto the thread stud and tightening it with the spanner.

1. INSTALLATION DIMENSIONS:

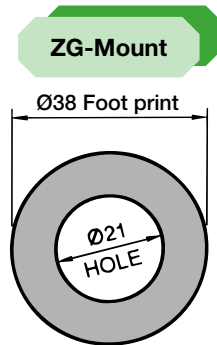

Build-in depth: 10.5 mm

2. INSTALLATION STEPS:

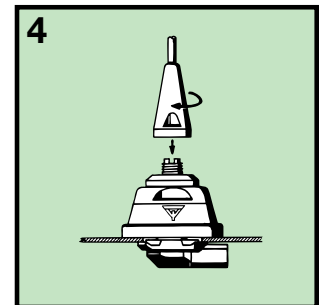
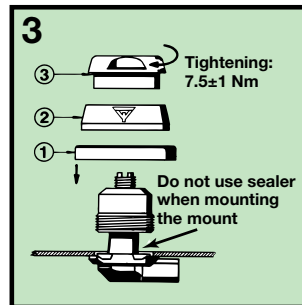
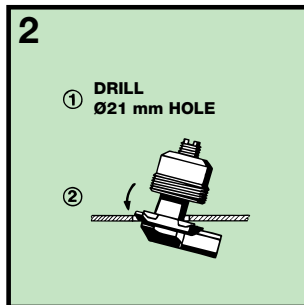
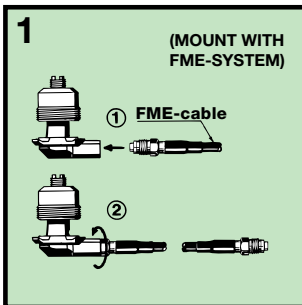

3. TUNING:

The antenna is delivered factory-tuned and requires no further tuning.