

X-Mount

Stream-lined Mobile Mount



DESCRIPTION:

- ★ Mobile mount with a nice, “streamline”-look, which can be installed everywhere on the car in an 18 mm dia. hole.
- ★ Especially suited for mounting on the narrow strip on rear wing between trunk lid and car side.
- ★ M6 thread whip-mounting system.
- ★ Very low requirements to installation depth both under and after installation.
- ★ Designed for installation with access from the outside only.
- ★ With access available from the inside, installation is possible in a 14 mm dia. hole.
- ★ Bendable section in mount makes whip tiltable 30° by hand.
- ★ Complete line of whips available for all communications bands up to 1300 MHz.
- ★ Mounting body made of stainless steel !
- ★ Choice between two connection principles:
 - ★ X-mount : FME-connection (supplied without cable).
 - ★ XP4-mount : Permanently attached 4 m cable terminated with FME-connector.

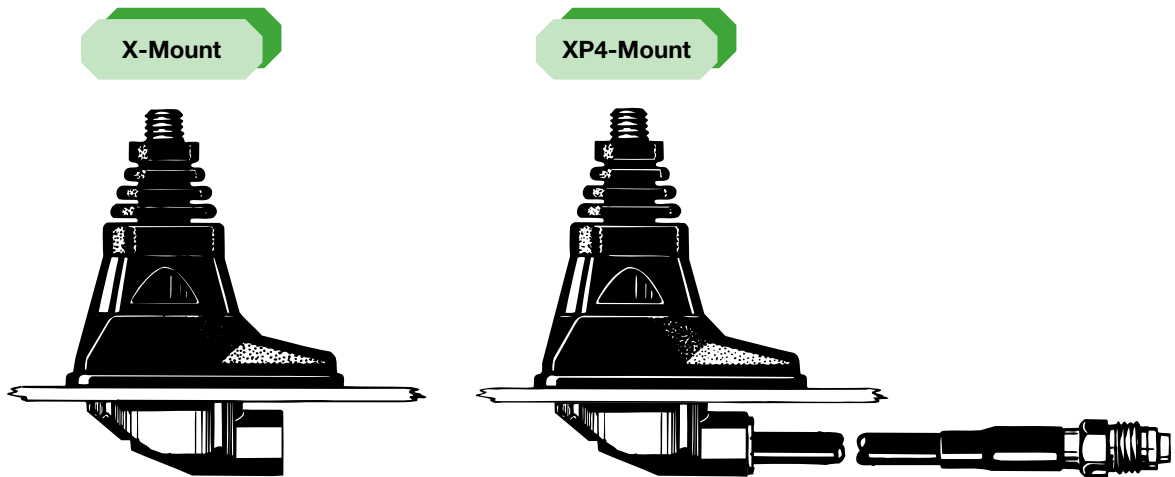

ORDERING DESIGNATIONS:

VERSION	X-mount with FME-system	XP4-mount with 4 m cable and FME-connector
TYPE NO.	X-Mount	XP4-Mount

SPECIFICATIONS:

APPLICATION	Mount for mobile antennas
FREQUENCY	0-1300 MHz
CONNECTION TO WHIP	M6 thread stud
MATERIALS	Stainless steel Black chromed brass Cu-nite brass Environment-proof plastics
COLOUR	Black
HEIGHT	Approx. 44 mm
LENGTH/WIDTH	41.5mm/27.5 mm
BUILD-IN DEPTH	Active : 30 mm Passive : 11 mm
RECOMMENDED INSTALLATION TORQUE	4 ± 1 Nm
WEIGHT	X-version : Approx. 40 g XP4-version : Approx. 180 g
MOUNTING	18 mm dia. hole
ROOF THICKNESS	Max. 2 mm

FME-SYSTEM ACCESSORIES	
FME-CABLES	
LENGTH	TYPE NO.
1m	1m FME
2m	2m FME
3m	3m FME
4m	4m FME
5m	5m FME
6m	6m FME
4m white	4m FME-white
6m white	6m FME-white
12m white	12m FME-white
18m white	18m FME-white

For further information about other types of FME-cables please compare the cable data sheets under accessories in our catalogue.

FME-CONNECTORS	
CONNECTOR	ORDER NO.
FME-FME	FME-FME
Prolongation	FMEP
N	FME-N
FSMA	FME-FSMA
BNC	FME-BNC
TNC	FME-TNC
UHF	FME-UHF
Mini-UHF	FME-MUHF
Elbow-MUHF	FME-EMUHF
Elbow-BNC	FME-EBNC
Elbow-TNC	FME-ETNC
SMA	FME-SMA

PROCOM A/S reserve the right to amend specifications without prior notice.

X-Mount Installation



X-mount antenna types can be mounted anywhere on the car, however, roof top mounting is always recommended. The X-mount is able to be mounted on the often very narrow strip on the rear wing between the trunk lid and the side of the car. Mounting can take place exclusively with access from the outside when drilling an 18 mm dia. hole. Mounting can take place from the inside by drilling a 14 mm dia. hole, in which case the bottom plastic ring of the packing gasket should be removed with a sharp cutter.

A good contact surface on the inside of the car body must always be ensured, thus enabling the base plate to get in direct contact with the metal parts of the car, which is of utmost importance for proper performance of the antenna.

When cleaning the car in car-washing machines, the whip is easily removed using a fork spanner. The whip is refitted again by screwing it onto the thread stud and tightening it lightly with the spanner.

As the X-mount is internally equipped with a bendable section, the antennas can always be adjusted to an upright position independent of the tilt angle of the installation spot (up to 30° tilt).

1. INSTALLATION DIMENSIONS:

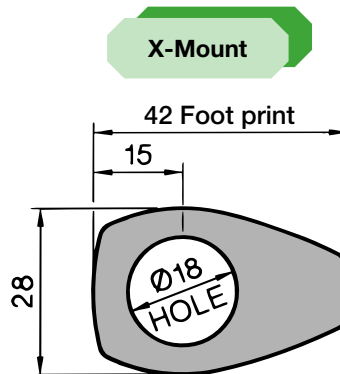

2. INSTALLATION STEPS:

